

- en** *Customer Contact Guide*
- es** *Guía de contacto del cliente*
- fr** *Guide de contacts pour le client*

Not for  
Reproduction

# Thank You

Thank you for purchasing this quality-built Simplicity® product. We are pleased that you have confidence in the Simplicity® brand. When operated and maintained according to the manuals, this product will provide many years of dependable service.

The Operator's Manual contains safety information to make you aware of the hazards and risks associated with the unit and how to avoid them. This product was designed to be used as described in the Operator's Manual and is not intended for any other purpose. It is important that you read and thoroughly understand the instructions in the manual before attempting to start, operate, or service the product. Save these original instructions for future reference.

This product requires final assembly, which is described in the Setup Instructions. Make sure to follow the instructions completely before use. If you need assistance with assembly, operation, or maintenance of the product, contact your local Authorized Service Dealer or visit [www.simplicitymfg.com](http://www.simplicitymfg.com) or call 1-800-837-6836 (in USA only).

## Register Your Product

To ensure prompt and complete warranty coverage, register your product on-line at [www.onlineproductregistration.com](http://www.onlineproductregistration.com).

## Identification Tag

Record the model name/number, manufacturer's identification numbers, and engine serial numbers in the space provided for easy access.

Product Model Number:	
Product Serial Number:	
Engine Model-Type Number:	
Engine Code/Serial Number:	
Date of Purchase:	
Purchase Location:	

When contacting the Authorized Dealer for replacement parts, service, or information you MUST have these numbers.

The Illustrated Parts List for this machine can be downloaded from [www.simplicitymfg.com](http://www.simplicitymfg.com). Please provide model and serial number when ordering replacement parts.

For the location of the identification tag (A), refer to the following illustration.

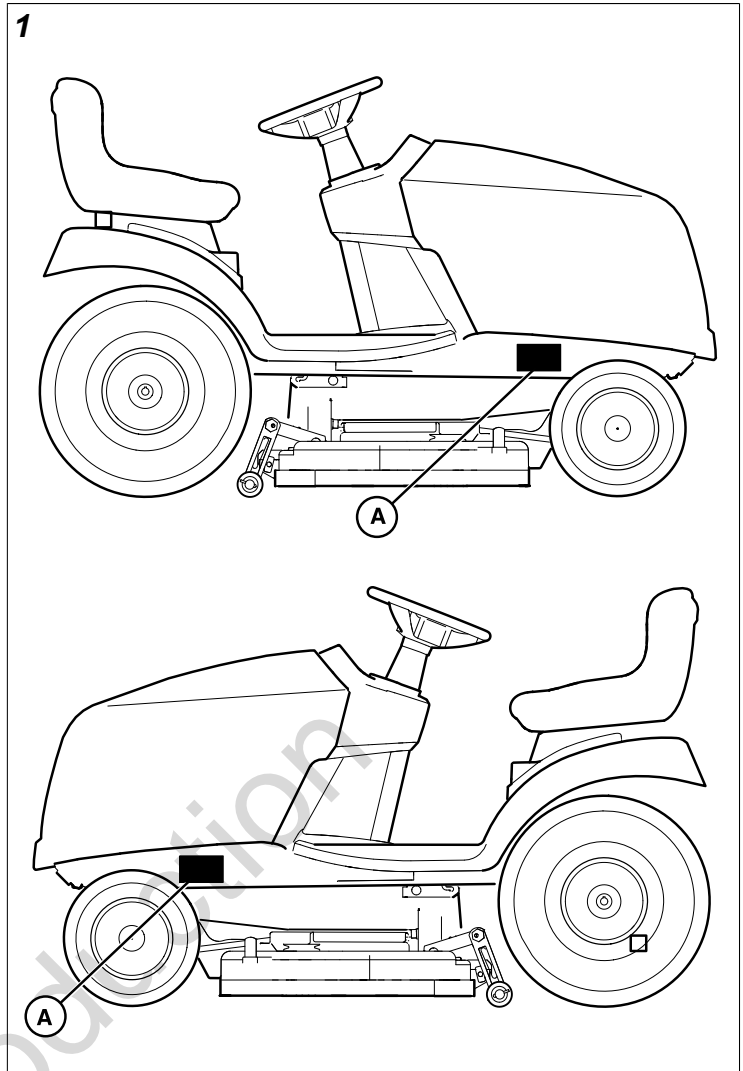

## Product Warranty

### Warranty Statement

#### LIMITED WARRANTY

Briggs & Stratton warrants that, during the warranty period specified below, it will repair or replace, free of charge, any part that is defective in material or workmanship or both. Transportation charges on product submitted for repair or replacement under this warranty must be borne by purchaser. This warranty is effective for and is subject to the time periods and conditions stated below. For warranty service, find the nearest Authorized Service Dealer in our dealer locator map at [www.simplicitymfg.com](http://www.simplicitymfg.com).

The purchaser must contact the Authorized Service Dealer, and then make the product available to the Authorized Service Dealer for inspection and testing.

**There is no other express warranty. Implied warranties, including those of merchantability and fitness for a particular purpose, are limited to the warranty period listed below, or to the extent permitted by law. Liability for incidental or consequential damages are excluded to the extent exclusion is permitted by law.** Some states or countries do not allow limitations on how long an implied warranty lasts, and some states or countries do not allow

the exclusion or limitation of incidental or consequential damages, so the above limitation and exclusion may not apply to you. This warranty gives you specific legal rights and you may also have other rights which vary from state to state or country to country.\*\*

## Warranty Period

Item	Consumer Use	Commercial Use
Equipment	36 Months	3 Months
Engine*	36 Months	12 Months
Battery (if equipped)	12 Months	12 Months

\* Applies to Briggs & Stratton engines only. Warranty coverage of non-Briggs & Stratton engines is provided by that engine manufacturer. Emissions-related components are covered by the Emissions Warranty Statement.

\*\* In Australia - Our goods come with guarantees that cannot be excluded under the Australian Consumer Law. You are entitled to a replacement or refund for a major failure and for compensation for any other reasonably foreseeable loss or damage. You are also entitled to have the goods repaired or replaced if the goods fail to be of acceptable quality and the failure does not amount to a major failure. For warranty service, find the nearest Authorized Service Dealer in our dealer locator map at BRIGGSandSTRATTON.COM, or by calling 1300 274 447, or by emailing or writing to salesenquires@briggsandstratton.com.au, Briggs & Stratton Australia Pty Ltd, 1 Moorebank Avenue, NSW, Australia, 2170.

The warranty period begins on the date of purchase by the first retail or commercial consumer. "Consumer use" means personal residential household use by a retail consumer. "Commercial use" means all other uses, including use for commercial, income producing or rental purposes. Once a product has experienced commercial use, it shall thereafter be considered as a commercial use product for purposes of this warranty.

To ensure prompt and complete warranty coverage, register your product at the website shown above or at [www.onlineproductregistration.com](http://www.onlineproductregistration.com).

Save your proof of purchase receipt. If you do not provide proof of the initial purchase date at the time warranty service is requested, the manufacturing date of the product will be used to determine the warranty period. Product registration is not required to obtain warranty service on Briggs & Stratton products.

## About Your Warranty

Warranty service is available only through Simplicity® Authorized Service Dealers. This warranty covers only defects in materials or workmanship. It does not cover damage caused by improper use or abuse, improper maintenance or repair, normal wear and tear, or stale or unapproved fuel.

**Improper Use and Abuse** - The proper, intended use of this product is described in the Operator's Manual. Using the product in a way not described in the Operator's Manual

or using the product after it has been damaged will not be covered under this warranty. Warranty coverage will also not be provided if the serial number on the product has been removed or the product has been altered or modified in any way, or if the product has evidence of abuse such as impact damage or water/chemical corrosion damage.

**Improper Maintenance or Repair** - This product must be maintained according to the procedures and schedules provided in the Operator's Manual, and serviced or repaired using genuine Briggs & Stratton parts or equivalent. Damage caused by lack of maintenance or use of non-original parts is not covered by warranty.

**Normal Wear and Tear** - Like most mechanical devices, your unit is subject to wear even when properly maintained. This warranty does not cover repairs when normal use has exhausted the life of a part or the equipment. Maintenance and wear items such as filters, belts, cutting blades, and brake pads (except engine brake pads) are not covered by warranty due to wear characteristics alone, unless the cause is due to defects in material or workmanship.

**Stale or Unapproved Fuel** - In order to function correctly, this product requires fresh fuel that conforms to the criteria specified in the Operator's Manual. Engine or equipment damage caused by stale fuel or the use of unapproved fuels (such as E15 or E85 ethanol blends) is not covered by warranty.

**Other Exclusions** - This warranty excludes damage due to accident, abuse, modifications, alterations, improper servicing, freezing or chemical deterioration. Attachments or accessories that were not originally packaged with the product are also excluded. There is no warranty coverage on equipment used for primary power in place of utility power or on equipment used in life support applications. This warranty does not include used, reconditioned, second-hand, or demonstration equipment or engines. This warranty also excludes failures due to acts of God and other force majeure events beyond the manufacturer's control.

80015795EN (Rev -)

## Briggs & Stratton Emissions Warranty

**California, U.S. EPA, and Briggs & Stratton Corporation Emissions Control Warranty - Your Warranty Rights and Obligations**

**For Briggs & Stratton Engine Models with "B" or "G" Trim Designation (Model-Type-Trim Representation xxxxxx xxxx Bx or xxxxxx xxxx Gx)**

The California Air Resources Board, U.S. EPA, and Briggs & Stratton (B&S) are pleased to explain the exhaust emissions ("emissions") control system warranty on your 2018-2020 engine. In California, new equipment that use small off-road engines must be designed, built, and equipped to meet the State's stringent anti-smog standards. B&S must warrant the emissions control system on your engine for the periods of time listed below provided there has been no abuse, neglect or improper maintenance of your small off-road

engine or equipment leading to the failure of the emissions control system.

Your emissions control system may include parts such as the carburetor or fuel-injection system, the ignition system, catalytic converter, fuel tanks, fuel lines (for liquid fuel and fuel vapors), fuel caps, valves, canisters, filters, clamps and other associated components. Also included may be hoses, belts, connectors, and other emission-related assemblies.

Where a warrantable condition exists, B&S will repair your engine at no cost to you including diagnosis, parts, and labor.

#### **Manufacturer's Warranty Coverage:**

The exhaust emissions control system on your engine is warranted for two years. If any emissions-related part on your engine is defective, the part will be repaired or replaced by B&S.

#### **Owner's Warranty Responsibilities:**

- As the engine owner, you are responsible for the performance of the required maintenance listed in your owner's manual. B&S recommends that you retain all receipts covering maintenance on your engine, but B&S cannot deny warranty coverage solely for the lack of receipts or for your failure to ensure the performance of all scheduled maintenance.
- As the engine owner, you should however be aware that B&S may deny you warranty coverage if your engine or a part has failed due to abuse, neglect, or improper maintenance or unapproved modifications.
- You are responsible for presenting your engine to a B&S distribution center or service center as soon as the problem exists. The warranty repairs shall be completed in a reasonable amount of time, not to exceed 30 days. If you have a question regarding your warranty rights and responsibilities, you should contact B&S at 1-800-444-7774 (in USA) or BRIGGSandSTRATTON.COM.

#### **Briggs & Stratton Emissions Control Warranty Provisions**

The following are specific provisions relative to your Emissions Control Warranty Coverage. It is in addition to the B&S engine warranty for non-regulated engines found in the Operator's Manual.

##### **1. Warranted Emissions Parts**

Coverage under this warranty extends only to the parts listed below (the emissions control systems parts) to the extent these parts were present on the B&S engine.

###### **a. Fuel Metering System**

- Cold start enrichment system (soft choke)
- Carburetor or fuel injection system
- Oxygen sensor
- Electronic control unit
- Fuel pump module

###### **b. Air Induction System**

- Air cleaner

- Intake manifold

###### **c. Ignition System**

- Spark plug(s)
- Magneto ignition system

###### **d. Catalyst System**

- Catalytic converter
- Exhaust manifold
- Air injection system or pulse valve

###### **e. Miscellaneous Items Used in Above Systems**

- Vacuum, temperature, position, time sensitive valves and switches
- Connectors and assemblies
- Electronic controls

##### **2. Length of Coverage**

Coverage is for a period of two years from the date of delivery to an ultimate purchaser, or for the time period listed in the respective engine or product warranty statement, whichever is greater. B&S warrants to the original purchaser and each subsequent purchaser that the engine is designed, built, and equipped so as to conform with all applicable regulations adopted by the Air Resources Board; that it is free from defects in material and workmanship that could cause the failure of a warranted part; and that it is identical in all material respects to the engine described in the manufacturer's application for certification. The warranty period begins on the date the engine or equipment is delivered to an ultimate purchaser.

The warranty on emissions-related parts is as follows:

- Any warranted part that is not scheduled for replacement as required maintenance in the Operator's Manual supplied, is warranted for the warranty period stated above. If any such part fails during the period of warranty coverage, the part will be repaired or replaced by B&S at no charge to the owner. Any such part repaired or replaced under the warranty will be warranted for the remaining warranty period.
- Any warranted part that is scheduled only for regular inspection in the Operator's Manual supplied, is warranted for the warranty period stated above. Any such part repaired or replaced under warranty will be warranted for the remaining warranty period.
- Any warranted part that is scheduled for replacement as required maintenance in the Operator's Manual supplied, is warranted for the period of time prior to the first scheduled replacement point for that part. If the part fails prior to the first scheduled replacement, the part will be repaired or replaced by B&S at no charge to the owner. Any such part repaired or replaced under warranty will be warranted for the remainder of the period prior to the first scheduled replacement point for the part.

- Add-on or modified parts that are not exempted by the Air Resources Board may not be used. The use of any non-exempted add-on or modified parts by the owner will be grounds for disallowing a warranty claim. The manufacturer will not be liable to warrant failures of warranted parts caused by the use of a non-exempted add-on or modified part.

3. Consequential Coverage

Coverage shall extend to the failure of any engine components caused by the failure of any warranted emissions parts.

4. Claims and Coverage Exclusions

Warranty claims shall be filed according to the provisions of the B&S engine warranty policy. Warranty coverage does not apply to failures of emissions parts that are not original equipment B&S parts or to parts that fail due to abuse, neglect, or improper maintenance as set forth in the B&S engine warranty policy. B&S is not liable for warranty coverage of failures of emissions parts caused by the use of add-on or modified parts.

**Look For Relevant Emissions Durability Period and Air Index Information On Your Small Off-Road Engine Emissions Label**

Engines that are certified to meet the California Air Resources Board (CARB) small off-road Emissions Standard must display information regarding the Emissions Durability Period and the Air Index. Briggs & Stratton makes this information available to the consumer on our emissions labels. The engine emissions label will indicate certification information.

The **Emissions Durability Period** describes the number of hours of actual running time for which the engine is certified to be emissions compliant, assuming proper maintenance in accordance with the Operator's Manual. The following categories are used:

**Moderate:**

Engines at or less than 80 cc displacement are certified to be emissions compliant for 50 hours of actual engine running time. Engines greater than 80 cc displacement are certified to be emissions compliant for 125 hours of actual engine running time.

**Intermediate:**

Engines at or less than 80 cc displacement are certified to be emissions compliant for 125 hours of actual engine running time. Engines greater than 80 cc displacement are certified to be emissions compliant for 250 hours of actual engine running time.

**Extended:**

Engines at or less than 80 cc displacement are certified to be emissions compliant for 300 hours of actual engine running time. Engines greater than 80 cc displacement are certified to be emissions compliant for 500 hours of actual engine running time.

For example, a typical walk-behind lawn mower is used 20 to 25 hours per year. Therefore, the **Emissions Durability**

**Period** of an engine with an **intermediate** rating would equate to 10 to 12 years.

Briggs & Stratton engines are certified to meet the United States Environmental Protection Agency (USEPA) Phase 2 or Phase 3 emissions standards. The Emissions Compliance Period referred to on the Emissions Compliance label indicates the number of operating hours for which the engine has been shown to meet Federal emissions requirements.

**For engines at or less than 80 cc displacement:**

Category C = 50 hours, Category B = 125 hours, Category A = 300 hours

**For engines greater than 80 cc displacement and less than 225 cc displacement:**

Category C = 125 hours, Category B = 250 hours, Category A = 500 hours

**For engines of 225 cc or more displacement:**

Category C = 250 hours, Category B = 500 hours, Category A = 1000 hours

80008114EN (Rev G)

# Gracias

Gracias por comprar este producto Simplicity® de alta calidad. Nos complace que confíe en la marca Simplicity®. Si se usa y se le da mantenimiento según las instrucciones en los manuales, este producto le proporcionará muchos años de servicio confiable.

El Manual del operador contiene información de seguridad para que usted conozca los peligros y riesgos propios de la unidad y sepa cómo evitarlos. Este producto está diseñado para utilizarse tal y como se describe en el Manual del operador y no puede usarse para ningún otro fin. Es importante que lea y comprenda perfectamente las instrucciones de este manual antes de intentar arrancar o usar este equipo. Conserve estas instrucciones originales para futuras consultas.

Este producto requiere un montaje final que se describe en las instrucciones de montaje. Asegúrese de seguir completamente las instrucciones antes de usar. Si necesita ayuda con el montaje, la operación o el mantenimiento del producto, comuníquese con su distribuidor de servicio autorizado o visite [www.simplicitymfg.com](http://www.simplicitymfg.com) o llame al 1-800-837-6836 (solo en los EE. UU.).

## Registre su producto

Con el fin de garantizar la cobertura de la garantía de forma oportuna y completa, registre su producto en línea en [www.onlineproductregistration.com](http://www.onlineproductregistration.com).

## Identification Tag

Record the model name/number, manufacturer's identification numbers, and engine serial numbers in the space provided for easy access.

Product Model Number:	
Product Serial Number:	
Engine Model-Type Number:	
Engine Code/Serial Number:	
Date of Purchase:	
Purchase Location:	

When contacting the Authorized Dealer for replacement parts, service, or information you **MUST** have these numbers.

The Illustrated Parts List for this machine can be downloaded from [www.simplicitymfg.com](http://www.simplicitymfg.com). Please provide model and serial number when ordering replacement parts.

For the location of the identification tag (A), refer to the following illustration.

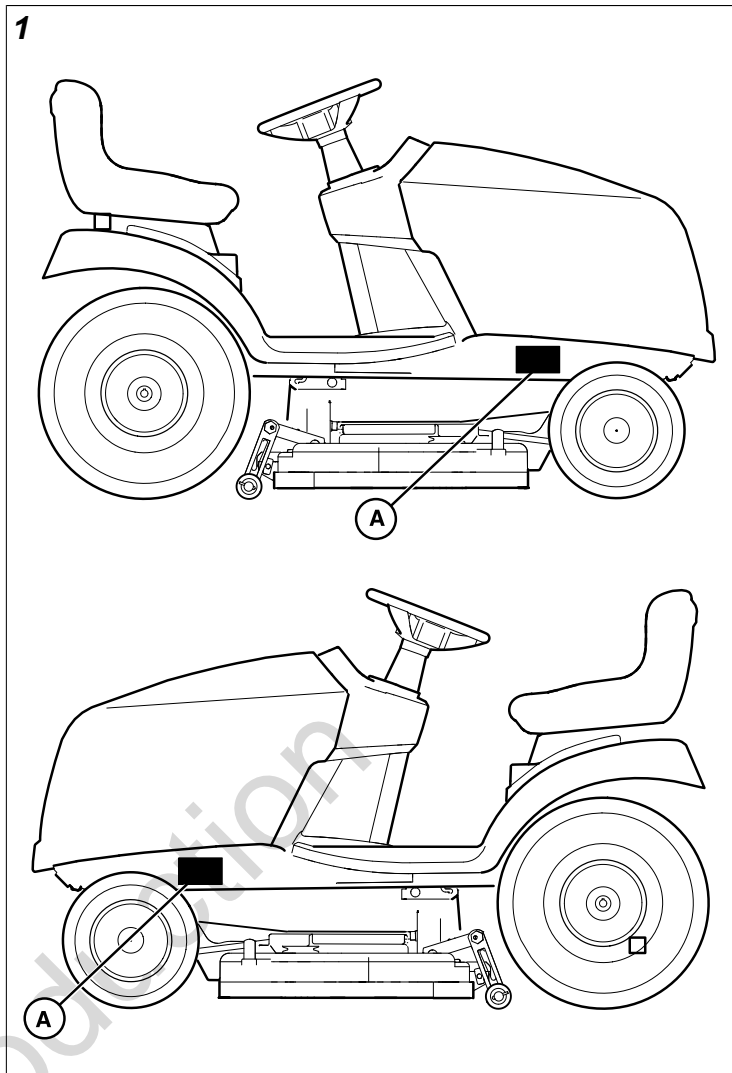

## Garantía del producto

### Periodo de garantía

Ítem	Uso privado	Uso comercial
Equipo	36 meses	3 meses
Motor*	36 meses	12 meses
Batería (si tuviera)	12 meses	12 meses

\* Solo aplicable a los motores Briggs & Stratton. La cobertura de garantía de motores diferentes a los Briggs and Stratton la suministra el fabricante del motor. Los componentes relacionados con las emisiones se tratan en la Declaración de Garantía sobre las Emisiones.

\*\* En Australia: nuestros productos vienen con garantías que no se pueden excluir en virtud de la Ley australiana de protección al consumidor. Usted tiene derecho a una sustitución o a un reembolso por una avería importante y a compensación por cualquier otra pérdida o daño razonablemente previsible. También tiene derecho a una reparación o sustitución de productos si estos no son de una calidad aceptable y la avería no asciende a una avería más importante. Para recibir servicio de garantía, contacte al distribuidor de servicio autorizado más cercano en nuestro mapa de localización de distribuidores en [BRIGGSandSTRATTON.COM](http://BRIGGSandSTRATTON.COM),

llame al 1300 274 447, o envíe un correo electrónico a [salesenquires@briggsandstratton.com.au](mailto:salesenquires@briggsandstratton.com.au) o una carta a Briggs & Stratton Australia Pty Ltd, 1 Moorebank Avenue, NSW, Australia, 2170.

El periodo de garantía inicia con la fecha de compra por parte del primer minorista o el comprador final. "Uso privado" significa uso doméstico personal por parte de un consumidor final. "Uso comercial" significa todos los demás usos, incluidos los usos con fines comerciales, de generación de ingresos o alquiler. Una vez que el producto haya sido usado de forma comercial, será considerado a partir de ese momento como un producto de uso comercial para los efectos de esta garantía.

Para asegurar una pronta y completa cobertura de garantía, registre su producto en el sitio web indicado anteriormente o en [www.onlineproductregistration.com](http://www.onlineproductregistration.com).

Guarde su recibo de comprobante de compra. Si no aporta un comprobante de la fecha de compra inicial al solicitar el servicio de garantía, se tomará la fecha de fabricación del producto para determinar el período de garantía. No se requiere el registro del producto para obtener el servicio de garantía en los productos de Briggs & Stratton.

## Acerca de su garantía

El servicio de garantía solo está disponible a través de los distribuidores de servicio autorizados de Simplicity®. Esta garantía solo cubre defectos de materiales o mano de obra. No cubre daños causados por uso indebido o maltrato, mantenimiento o reparación inadecuados, desgaste natural por uso, o el uso de un combustible viciado o inadecuado.

**Uso inadecuado y abuso:** el uso adecuado, para el cual está diseñado este producto se describe en el Manual del operador. La presente garantía no cubrirá el uso del producto de alguna forma no especificada en el Manual del operador o si este es utilizado después de haberse dañado. Además, no se entregará cobertura por garantía si el número de serie en el producto ha sido retirado o el producto ha sido alterado o modificado de alguna forma o si el producto presenta evidencias de abuso, tales como daño por impacto o daño por agua o corrosión química.

**Mantenimiento o reparación inadecuados:** el mantenimiento de este producto debe realizarse de acuerdo con los procedimientos y programaciones proporcionados en el Manual del operador y su servicio o reparación deben ser realizados con piezas Briggs & Stratton genuinas o equivalentes. Los daños causados por falta de mantenimiento o uso de piezas no originales no están cubiertos por la garantía.

**Desgaste normal:** como la mayoría de los dispositivos mecánicos, su unidad está sujeta a desgaste, inclusive con el mantenimiento adecuado. Esta garantía no cubre las reparaciones cuando el uso regular ha agotado la vida útil del equipo o de alguna de sus piezas. La garantía no cubre los artículos fungibles y que requieren reparación como los filtros, las correas, cuchillas y pastillas de freno (a excepción de las pastillas del motor) solamente por razones

de desgaste, a menos que existan defectos de material o de mano de obra.

**Combustible en mal estado o no aprobado:** para funcionar correctamente, este producto requiere combustible nuevo que cumpla con los criterios especificados en el Manual del operador. El motor o los equipos dañados a causa de combustible en mal estado o por el uso de combustibles no aprobados (como las mezclas de etanol E15 o E85) no están cubiertos por la garantía.

**Otras exclusiones:** esta garantía excluye los daños debido a accidentes, abusos, modificaciones, alteraciones, mantenimiento indebido, deterioro por congelamiento o químico. Se excluyen también los aditamentos o accesorios que no venían embalados con el producto. No existe la cobertura de garantía cuando el equipo es utilizado con una fuente primaria eléctrica en lugar de la red de servicios públicos, o un equipo empleado para el mantenimiento de las funciones vitales. Esta garantía no incluye a equipos o motores usados, reacondicionados, de segunda mano o para demostración. Esta garantía también excluye las fallas debido a hechos fortuitos y a otros acontecimientos de fuerza mayor que escapan al control del fabricante.

80015795EN (Rev. -)

## Briggs & Stratton Emissions Warranty

**California, U.S. EPA, and Briggs & Stratton Corporation Emissions Control Warranty - Your Warranty Rights and Obligations**

**For Briggs & Stratton Engine Models with "B" or "G" Trim Designation (Model-Type-Trim Representation xxxxxx xxxx Bx or xxxxxx xxxx Gx)**

The California Air Resources Board, U.S. EPA, and Briggs & Stratton (B&S) are pleased to explain the exhaust emissions ("emissions") control system warranty on your 2018-2020 engine. In California, new equipment that use small off-road engines must be designed, built, and equipped to meet the State's stringent anti-smog standards. B&S must warrant the emissions control system on your engine for the periods of time listed below provided there has been no abuse, neglect or improper maintenance of your small off-road engine or equipment leading to the failure of the emissions control system.

Your emissions control system may include parts such as the carburetor or fuel-injection system, the ignition system, catalytic converter, fuel tanks, fuel lines (for liquid fuel and fuel vapors), fuel caps, valves, canisters, filters, clamps and other associated components. Also included may be hoses, belts, connectors, and other emission-related assemblies.

Where a warrantable condition exists, B&S will repair your engine at no cost to you including diagnosis, parts, and labor.

### Manufacturer's Warranty Coverage:

The exhaust emissions control system on your engine is warranted for two years. If any emissions-related part on your engine is defective, the part will be repaired or replaced by B&S.

## Owner's Warranty Responsibilities:

- As the engine owner, you are responsible for the performance of the required maintenance listed in your owner's manual. B&S recommends that you retain all receipts covering maintenance on your engine, but B&S cannot deny warranty coverage solely for the lack of receipts or for your failure to ensure the performance of all scheduled maintenance.
- As the engine owner, you should however be aware that B&S may deny you warranty coverage if your engine or a part has failed due to abuse, neglect, or improper maintenance or unapproved modifications.
- You are responsible for presenting your engine to a B&S distribution center or service center as soon as the problem exists. The warranty repairs shall be completed in a reasonable amount of time, not to exceed 30 days. If you have a question regarding your warranty rights and responsibilities, you should contact B&S at 1-800-444-7774 (in USA) or BRIGGSandSTRATTON.COM.

## Briggs & Stratton Emissions Control Warranty Provisions

The following are specific provisions relative to your Emissions Control Warranty Coverage. It is in addition to the B&S engine warranty for non-regulated engines found in the Operator's Manual.

### 1. Warranted Emissions Parts

Coverage under this warranty extends only to the parts listed below (the emissions control systems parts) to the extent these parts were present on the B&S engine.

#### a. Fuel Metering System

- Cold start enrichment system (soft choke)
- Carburetor or fuel injection system
- Oxygen sensor
- Electronic control unit
- Fuel pump module

#### b. Air Induction System

- Air cleaner
- Intake manifold

#### c. Ignition System

- Spark plug(s)
- Magneto ignition system

#### d. Catalyst System

- Catalytic converter
- Exhaust manifold
- Air injection system or pulse valve

#### e. Miscellaneous Items Used in Above Systems

- Vacuum, temperature, position, time sensitive valves and switches
- Connectors and assemblies
- Electronic controls

### 2. Length of Coverage

C coverage is for a period of two years from the date of delivery to an ultimate purchaser, or for the time period listed in the respective engine or product warranty statement, whichever is greater. B&S warrants to the original purchaser and each subsequent purchaser that the engine is designed, built, and equipped so as to conform with all applicable regulations adopted by the Air Resources Board; that it is free from defects in material and workmanship that could cause the failure of a warranted part; and that it is identical in all material respects to the engine described in the manufacturer's application for certification. The warranty period begins on the date the engine or equipment is delivered to an ultimate purchaser.

The warranty on emissions-related parts is as follows:

- Any warranted part that is not scheduled for replacement as required maintenance in the Operator's Manual supplied, is warranted for the warranty period stated above. If any such part fails during the period of warranty coverage, the part will be repaired or replaced by B&S at no charge to the owner. Any such part repaired or replaced under the warranty will be warranted for the remaining warranty period.
  - Any warranted part that is scheduled only for regular inspection in the Operator's Manual supplied, is warranted for the warranty period stated above. Any such part repaired or replaced under warranty will be warranted for the remaining warranty period.
  - Any warranted part that is scheduled for replacement as required maintenance in the Operator's Manual supplied, is warranted for the period of time prior to the first scheduled replacement point for that part. If the part fails prior to the first scheduled replacement, the part will be repaired or replaced by B&S at no charge to the owner. Any such part repaired or replaced under warranty will be warranted for the remainder of the period prior to the first scheduled replacement point for the part.
  - Add-on or modified parts that are not exempted by the Air Resources Board may not be used. The use of any non-exempted add-on or modified parts by the owner will be grounds for disallowing a warranty claim. The manufacturer will not be liable to warrant failures of warranted parts caused by the use of a non-exempted add-on or modified part.
- ### 3. Consequential Coverage
- Coverage shall extend to the failure of any engine components caused by the failure of any warranted emissions parts.
- ### 4. Claims and Coverage Exclusions
- Warranty claims shall be filed according to the provisions of the B&S engine warranty policy. Warranty coverage does not apply to failures of emissions parts that are not original equipment B&S parts or to parts that fail due to abuse, neglect, or improper maintenance as set forth in the B&S engine warranty policy. B&S is not liable for



warranty coverage of failures of emissions parts caused by the use of add-on or modified parts.

Category C = 250 hours, Category B = 500 hours, Category A = 1000 hours

### **Look For Relevant Emissions Durability Period and Air Index Information On Your Small Off-Road Engine Emissions Label**

80008114EN (Rev G)

Engines that are certified to meet the California Air Resources Board (CARB) small off-road Emissions Standard must display information regarding the Emissions Durability Period and the Air Index. Briggs & Stratton makes this information available to the consumer on our emissions labels. The engine emissions label will indicate certification information.

The **Emissions Durability Period** describes the number of hours of actual running time for which the engine is certified to be emissions compliant, assuming proper maintenance in accordance with the Operator's Manual. The following categories are used:

#### **Moderate:**

Engines at or less than 80 cc displacement are certified to be emissions compliant for 50 hours of actual engine running time. Engines greater than 80 cc displacement are certified to be emissions compliant for 125 hours of actual engine running time.

#### **Intermediate:**

Engines at or less than 80 cc displacement are certified to be emissions compliant for 125 hours of actual engine running time. Engines greater than 80 cc displacement are certified to be emissions compliant for 250 hours of actual engine running time.

#### **Extended:**

Engines at or less than 80 cc displacement are certified to be emissions compliant for 300 hours of actual engine running time. Engines greater than 80 cc displacement are certified to be emissions compliant for 500 hours of actual engine running time.

For example, a typical walk-behind lawn mower is used 20 to 25 hours per year. Therefore, the **Emissions Durability Period** of an engine with an **intermediate** rating would equate to 10 to 12 years.

Briggs & Stratton engines are certified to meet the United States Environmental Protection Agency (USEPA) Phase 2 or Phase 3 emissions standards. The Emissions Compliance Period referred to on the Emissions Compliance label indicates the number of operating hours for which the engine has been shown to meet Federal emissions requirements.

#### **For engines at or less than 80 cc displacement:**

Category C = 50 hours, Category B = 125 hours, Category A = 300 hours

#### **For engines greater than 80 cc displacement and less than 225 cc displacement:**

Category C = 125 hours, Category B = 250 hours, Category A = 500 hours

#### **For engines of 225 cc or more displacement:**

## Merci

Nous vous remercions d'avoir acheté ce produit de marque Simplicity® de grande qualité. Nous sommes heureux que vous ayez confiance en la marque Simplicity®. S'il est utilisé et entretenu selon les instructions des manuels, ce produit vous procurera de nombreuses années de service fiable.

Le manuel d'utilisation contient des renseignements de sécurité pour vous faire connaître les dangers et les risques associés à ce produit ainsi que la façon de les éviter. Ce produit a été conçu pour être utilisé tel que décrit dans le manuel d'utilisation et n'est pas destiné à d'autres fins. Il est important de lire et comprendre parfaitement les instructions de ce manuel avant d'essayer de mettre en marche, de faire fonctionner, ou de réparer le produit. Conservez ces instructions d'origine pour vous y reporter dans le futur.

Ce produit demande un assemblage final, qui est décrit dans les instructions de montage. S'assurer de suivre les instructions au complet avant de l'utiliser. Si vous avez besoin d'aide pour le montage, l'utilisation ou l'entretien de ce produit, veuillez communiquer avec votre fournisseur de service autorisé local ou visiter [www.simplicitymfg.com](http://www.simplicitymfg.com) ou appeler 1-800-837-6836 (aux États-Unis seulement).

## Enregistrer votre produit

Pour assurer une couverture rapide et complète de la garantie, veuillez enregistrer votre produit en ligne à [www.onlineproductregistration.com](http://www.onlineproductregistration.com).

## Identification Tag

Record the model name/number, manufacturer's identification numbers, and engine serial numbers in the space provided for easy access.

Product Model Number:	
Product Serial Number:	
Engine Model-Type Number:	
Engine Code/Serial Number:	
Date of Purchase:	
Purchase Location:	

When contacting the Authorized Dealer for replacement parts, service, or information you MUST have these numbers.

The Illustrated Parts List for this machine can be downloaded from [www.simplicitymfg.com](http://www.simplicitymfg.com). Please provide model and serial number when ordering replacement parts.

For the location of the identification tag (A), refer to the following illustration.

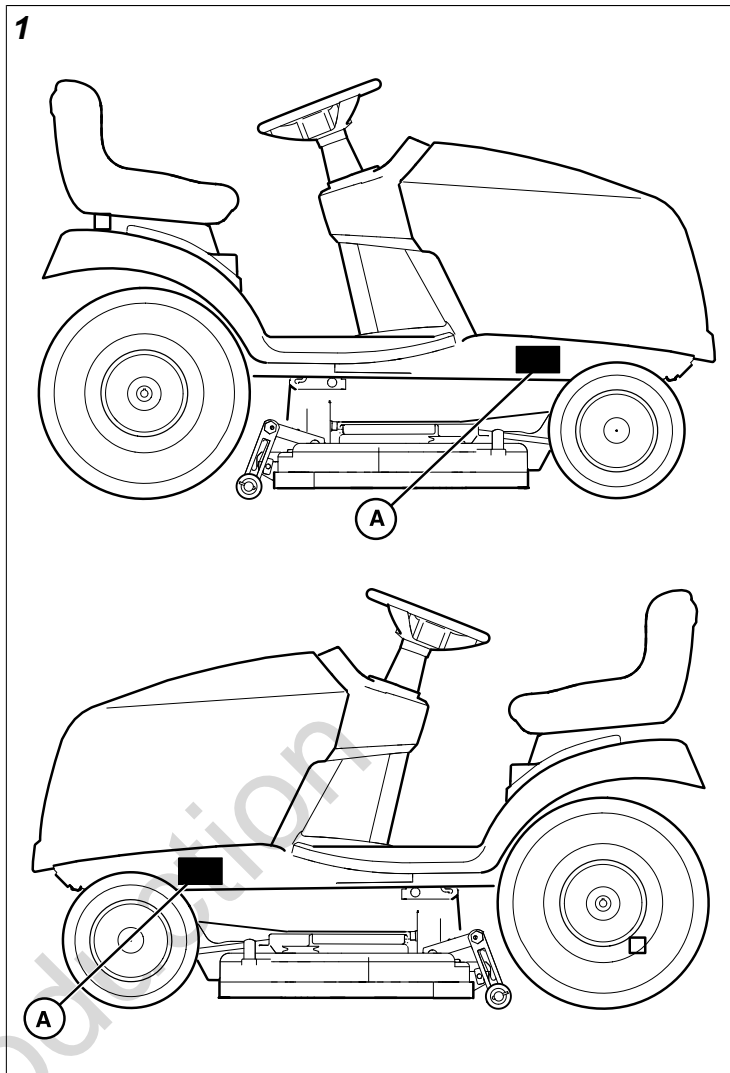

## Garantie du produit

### Énoncé de garantie

#### GARANTIE LIMITÉE

Briggs & Stratton garantit que, pendant la période de couverture de la garantie précisée ci-dessous, elle réparera ou remplacera, sans frais, toute pièce défectueuse comportant un vice de matériau ou un défaut de fabrication ou les deux. En vertu de la présente garantie, les frais de transport du produit soumis pour réparation ou remplacement sont à la charge de l'acheteur. La présente garantie sera en vigueur et soumise aux périodes et conditions stipulées ci-dessous. Pour obtenir des services en vertu de la garantie, veuillez consulter notre Outil de recherche d'un Service après-vente agréé à [www.simplicitymfg.com](http://www.simplicitymfg.com), afin de trouver un distributeur de service après-vente agréé dans votre région.

L'acheteur doit communiquer avec le distributeur de service autorisé et mettre ensuite le produit à disposition du distributeur de service autorisé pour inspection et essai.

**Il n'existe aucune autre garantie expresse. Les garanties implicites, incluant les garanties de qualité marchande et d'adaptation à un usage particulier, sont limitées à la période définie dans la garantie citée ci-dessous, ou**

**jusqu'à la limite permise par la loi. La responsabilité pour dommages accessoires ou indirects est exclue dans la mesure où une telle exclusion est permise par la loi.** Certains états/provinces ou pays n'autorisent aucune restriction sur la durée d'une garantie implicite, et certains états/provinces ou pays n'autorisent pas l'exclusion ou la limitation des dommages consécutifs ou indirects. Par conséquent, les restrictions et exclusions décrites ci-dessus pourraient ne pas s'appliquer dans votre cas. La présente garantie vous offre des droits juridiques spécifiques et il se peut que vous ayez d'autres droits qui varient d'une juridiction à une autre, ou de pays à pays.\*\*

## Période de garantie

Article	Usage par un consommateur	Usage à des fins commerciales
Équipement	36 mois	3 mois
Moteur*	36 mois	12 mois
Batterie (si équipé)	12 mois	12 mois

\* Applicable aux moteurs Briggs & Stratton seulement. La couverture de garantie des moteurs qui ne sont pas fabriqués par Briggs & Stratton est fournie par le fabricant du moteur. Les composants antipollution sont couverts par la Déclaration de garantie concernant le contrôle des émissions.

\*\* En Australie – Nos produits sont livrés avec des garanties qui ne peuvent pas être exclues en vertu de la loi australienne sur la consommation. Vous avez droit à un remplacement ou à un remboursement en cas de défaillance majeure et en compensation pour toute perte ou tout dommage raisonnablement prévisible. Vous avez également droit à la réparation ou au remplacement des produits si ceux-ci ne sont pas de qualité acceptable et que la défaillance n'équivaut pas à une défaillance majeure. Pour obtenir le service sous garantie, recherchez le concessionnaire autorisé le plus proche sur notre carte des détaillants sur le site BRIGGSandSTRATTON.COM, appelez le 1300 274 447 ou encore envoyez un courriel ou une lettre à salesenquires@briggsandstratton.com.au, Briggs & Stratton Australia Pty Ltd, 1 Moorebank Avenue, NSW, Australie, 2170.

La période de garantie débute à la date d'achat par le premier acheteur au détail ou par le premier utilisateur commercial. « Usage par un consommateur » signifie que le produit sera utilisé par un consommateur au détail dans un but privé. « Usage commercial » indique toutes les autres utilisations possibles, y compris commerciales, génératrices de revenus ou locatives. Une fois que le produit a été utilisé dans un but commercial, il sera considéré comme d'utilisation commerciale dans le cadre de cette garantie.

Pour obtenir une couverture de garantie complète et rapide, veuillez enregistrer votre produit au site Web indiqué ci-dessus ou à [www.onlineproductregistration.com](http://www.onlineproductregistration.com).

Veuillez garder le reçu de votre achat. Si vous ne pouvez pas fournir la preuve de la date initiale de l'achat au moment de faire une demande se rapportant à la garantie, la date de fabrication du produit sera utilisée pour déterminer la période

de garantie. Pour exercer la garantie sur tout produit fabriqué par Briggs & Stratton, il n'est pas nécessaire de l'enregistrer.

## À propos de votre garantie

Les services liés à la garantie sont uniquement disponibles par l'entremise d'un distributeur de service autorisé Simplicity®. Cette garantie couvre uniquement les défauts de matériel et de fabrication. Elle ne couvre pas des dommages causés par une mauvaise utilisation ou par des abus, un mauvais entretien ou une réparation incorrecte, une usure normale ou l'utilisation de carburant éventé ou non approuvé.

**Utilisation inadéquate et abus** – Une bonne utilisation, tel que prévu, du produit est décrite dans le manuel de l'utilisateur. L'utilisation du produit de façon autre que celle décrite dans le manuel d'utilisation ou son utilisation une fois qu'il est endommagé annulera la garantie. Vous ne pourrez vous prévaloir de la garantie si le numéro de série sur la machine a été supprimé ou si la machine a été modifiée d'une manière quelconque, ou si elle présente des preuves d'abus, tel que par impact, corrosion par l'eau ou par produits chimiques.

**Mauvais entretien ou réparation** – Cette machine doit être entretenue conformément aux procédures et aux intervalles indiqués dans le manuel d'utilisation, l'entretien et les réparations doivent être effectués avec des pièces d'origine Briggs & Stratton ou équivalentes. Les dommages causés par le manque d'entretien ou l'utilisation de pièces n'étant pas d'origine ne sont pas couverts par la garantie.

**Usure normale** – Comme la plupart des appareils mécaniques, malgré un bon entretien, le vôtre est sujet à une usure. La présente garantie ne couvre pas les réparations lorsque la durée de vie d'une pièce ou de l'appareil s'est achevée après une utilisation normale. Les articles d'entretien et d'usure, tels que filtres, courroies, lames et plaquettes de frein (les plaquettes de frein du moteur sont couvertes) ne sont pas couverts par la garantie en raison de leur seule usure, à moins qu'ils ne soient sujets à des vices du matériel ou de fabrication.

**Carburant éventé ou non autorisé** – Afin de fonctionner correctement, ce produit doit être alimenté avec un carburant frais conforme au critère précisé dans le manuel d'utilisation. Les dommages au moteur ou à l'équipement dus à un carburant éventé ou à l'utilisation de carburants non approuvés (comme les mélanges d'éthanol E15 ou E85) ne sont pas couverts par la garantie.

**Autres exclusions** – La présente garantie exclut les dommages résultant d'un accident, d'une utilisation abusive, de modifications, de changements, d'un entretien inadéquat, du gel ou d'une détérioration chimique. Les accessoires non emballés à l'origine avec le produit sont aussi exclus. La garantie ne couvre pas l'équipement utilisé comme alimentation principale à la place de l'alimentation électrique de secteur ou pour les applications de maintien des fonctions vitales. Cette garantie n'inclut pas les appareils ou les moteurs usagés, réusinés, de seconde main ou de démonstration. Cette garantie exclut toute défaillance due à

une catastrophe naturelle ou à toute autre force majeure hors du contrôle du fabricant.

80015795EN (Rév -)

## Briggs & Stratton Emissions Warranty

### California, U.S. EPA, and Briggs & Stratton Corporation Emissions Control Warranty - Your Warranty Rights and Obligations

#### For Briggs & Stratton Engine Models with "B" or "G" Trim Designation (Model-Type-Trim Representation xxxxxx xxxx Bx or xxxxxx xxxx Gx)

The California Air Resources Board, U.S. EPA, and Briggs & Stratton (B&S) are pleased to explain the exhaust emissions ("emissions") control system warranty on your 2018-2020 engine. In California, new equipment that use small off-road engines must be designed, built, and equipped to meet the State's stringent anti-smog standards. B&S must warrant the emissions control system on your engine for the periods of time listed below provided there has been no abuse, neglect or improper maintenance of your small off-road engine or equipment leading to the failure of the emissions control system.

Your emissions control system may include parts such as the carburetor or fuel-injection system, the ignition system, catalytic converter, fuel tanks, fuel lines (for liquid fuel and fuel vapors), fuel caps, valves, canisters, filters, clamps and other associated components. Also included may be hoses, belts, connectors, and other emission-related assemblies.

Where a warrantable condition exists, B&S will repair your engine at no cost to you including diagnosis, parts, and labor.

#### Manufacturer's Warranty Coverage:

The exhaust emissions control system on your engine is warranted for two years. If any emissions-related part on your engine is defective, the part will be repaired or replaced by B&S.

#### Owner's Warranty Responsibilities:

- As the engine owner, you are responsible for the performance of the required maintenance listed in your owner's manual. B&S recommends that you retain all receipts covering maintenance on your engine, but B&S cannot deny warranty coverage solely for the lack of receipts or for your failure to ensure the performance of all scheduled maintenance.
- As the engine owner, you should however be aware that B&S may deny you warranty coverage if your engine or a part has failed due to abuse, neglect, or improper maintenance or unapproved modifications.
- You are responsible for presenting your engine to a B&S distribution center or service center as soon as the problem exists. The warranty repairs shall be completed in a reasonable amount of time, not to exceed 30 days. If you have a question regarding your warranty rights and responsibilities, you should contact B&S at 1-800-444-7774 (in USA) or BRIGGSandSTRATTON.COM.

## Briggs & Stratton Emissions Control Warranty Provisions

The following are specific provisions relative to your Emissions Control Warranty Coverage. It is in addition to the B&S engine warranty for non-regulated engines found in the Operator's Manual.

1. Warranted Emissions Parts  
Coverage under this warranty extends only to the parts listed below (the emissions control systems parts) to the extent these parts were present on the B&S engine.
  - a. Fuel Metering System
    - Cold start enrichment system (soft choke)
    - Carburetor or fuel injection system
    - Oxygen sensor
    - Electronic control unit
    - Fuel pump module
  - b. Air Induction System
    - Air cleaner
    - Intake manifold
  - c. Ignition System
    - Spark plug(s)
    - Magneto ignition system
  - d. Catalyst System
    - Catalytic converter
    - Exhaust manifold
    - Air injection system or pulse valve
  - e. Miscellaneous Items Used in Above Systems
    - Vacuum, temperature, position, time sensitive valves and switches
    - Connectors and assemblies
    - Electronic controls
2. Length of Coverage  
C coverage is for a period of two years from the date of delivery to an ultimate purchaser, or for the time period listed in the respective engine or product warranty statement, whichever is greater. B&S warrants to the original purchaser and each subsequent purchaser that the engine is designed, built, and equipped so as to conform with all applicable regulations adopted by the Air Resources Board; that it is free from defects in material and workmanship that could cause the failure of a warranted part; and that it is identical in all material respects to the engine described in the manufacturer's application for certification. The warranty period begins on the date the engine or equipment is delivered to an ultimate purchaser.

The warranty on emissions-related parts is as follows:

- Any warranted part that is not scheduled for replacement as required maintenance in the Operator's Manual supplied, is warranted for the warranty period stated above. If any such part fails during the period of warranty coverage, the part will

be repaired or replaced by B&S at no charge to the owner. Any such part repaired or replaced under the warranty will be warranted for the remaining warranty period.

- Any warranted part that is scheduled only for regular inspection in the Operator's Manual supplied, is warranted for the warranty period stated above. Any such part repaired or replaced under warranty will be warranted for the remaining warranty period.
  - Any warranted part that is scheduled for replacement as required maintenance in the Operator's Manual supplied, is warranted for the period of time prior to the first scheduled replacement point for that part. If the part fails prior to the first scheduled replacement, the part will be repaired or replaced by B&S at no charge to the owner. Any such part repaired or replaced under warranty will be warranted for the remainder of the period prior to the first scheduled replacement point for the part.
  - Add-on or modified parts that are not exempted by the Air Resources Board may not be used. The use of any non-exempted add-on or modified parts by the owner will be grounds for disallowing a warranty claim. The manufacturer will not be liable to warrant failures of warranted parts caused by the use of a non-exempted add-on or modified part.
3. Consequential Coverage  
Coverage shall extend to the failure of any engine components caused by the failure of any warranted emissions parts.
4. Claims and Coverage Exclusions  
Warranty claims shall be filed according to the provisions of the B&S engine warranty policy. Warranty coverage does not apply to failures of emissions parts that are not original equipment B&S parts or to parts that fail due to abuse, neglect, or improper maintenance as set forth in the B&S engine warranty policy. B&S is not liable for warranty coverage of failures of emissions parts caused by the use of add-on or modified parts.

#### **Look For Relevant Emissions Durability Period and Air Index Information On Your Small Off-Road Engine Emissions Label**

Engines that are certified to meet the California Air Resources Board (CARB) small off-road Emissions Standard must display information regarding the Emissions Durability Period and the Air Index. Briggs & Stratton makes this information available to the consumer on our emissions labels. The engine emissions label will indicate certification information.

The **Emissions Durability Period** describes the number of hours of actual running time for which the engine is certified to be emissions compliant, assuming proper maintenance in accordance with the Operator's Manual. The following categories are used:

#### **Moderate:**

Engines at or less than 80 cc displacement are certified to be emissions compliant for 50 hours of actual engine running

time. Engines greater than 80 cc displacement are certified to be emissions compliant for 125 hours of actual engine running time.

#### **Intermediate:**

Engines at or less than 80 cc displacement are certified to be emissions compliant for 125 hours of actual engine running time. Engines greater than 80 cc displacement are certified to be emissions compliant for 250 hours of actual engine running time.

#### **Extended:**

Engines at or less than 80 cc displacement are certified to be emissions compliant for 300 hours of actual engine running time. Engines greater than 80 cc displacement are certified to be emissions compliant for 500 hours of actual engine running time.

For example, a typical walk-behind lawn mower is used 20 to 25 hours per year. Therefore, the **Emissions Durability Period** of an engine with an **intermediate** rating would equate to 10 to 12 years.

Briggs & Stratton engines are certified to meet the United States Environmental Protection Agency (USEPA) Phase 2 or Phase 3 emissions standards. The Emissions Compliance Period referred to on the Emissions Compliance label indicates the number of operating hours for which the engine has been shown to meet Federal emissions requirements.

#### **For engines at or less than 80 cc displacement:**

Category C = 50 hours, Category B = 125 hours, Category A = 300 hours

#### **For engines greater than 80 cc displacement and less than 225 cc displacement:**

Category C = 125 hours, Category B = 250 hours, Category A = 500 hours

#### **For engines of 225 cc or more displacement:**

Category C = 250 hours, Category B = 500 hours, Category A = 1000 hours

80008114EN (Rev G)

Not for  
Reproduction

Not for  
Reproduction

Not for  
Reproduction